

18. SKATES, PLATFORM HAND TRUCKS, LIFTING TABLES AND HAND TROLLEYS



SKATES

LIFTING TABLES

HAND TROLLEYS

PLATFORM HAND TRUCKS



SKATE 1500KG

- for moving machines and equipment
- duration oiled metal wheels
- groove in the centre of the wagon, for example, a wooden or metal beam, (width 75mm), which allow for joining several wagons
- CE marked

Maximum load	Height	Maximum width	Maximum length	Base measures	Weight	Product code
kg	mm	mm	mm	mm	appr. kg	
1500	68	185	200	100x200	5	SIALU15

SKATES 6000KG AND 8000KG

- for moving machines and equipment
- duration oiled, PU coated metal wheels
- moving extremely easily
- swivelling table in the centre of the wagon
- grip / pull handles on both sides
- CE marked

Max. load	Height	width	length	Base measures	Swivelling table diam.	Weight	Product code
kg	mm	mm	mm	mm	mm	appr. kg	
6000	110	208	295	166x208	147	17	SIALU60
8000	110	208	395	278x208	147	25	SIALU80

SKATES 3000KG AND 6000KG

- for moving machines and equipment
- duration oiled, PU coated metal wheels
- moving extremely easily
- CE marked

Max. load	Height	width	length	Base measures	Weight	Product code
kg	mm	mm	mm	mm	kg	
3000	106	230	405	330x191	9,4	SIALU3
6000	105	210	414	265x167	11,9	SIALU6

ADJUSTABLE SKATES 6000KG; 12000KG AND 24000KG

- for moving machines and equipment
- duration oiled nylon wheels (24000kg metal wheels)
- rubber surface on the wagon ensures good friction between the item and the skate
- delivered in pairs with transfer rods
- CE marked

Max. load	Height	width	length	Base measures	Weight	Adjustment	Product code
kg	mm	mm	mm	mm	appr. kg	mm	
6000	115	250	300	200x250	30	500 - 1400	SIALU6S
12000	115	220	360	200x350	38	720 - 1500	SIALU12S
24000	115	220	360	200x425	65	720 - 1500	SIALU24S



STEERABLE SKATES 3000KG; 6000KG AND 12000KG

- for moving machines and equipment
- duration oiled nylon wheels (12000kg metal wheels)
- fixed drawbar, which enables easy moving of the item
- the drawbar has an eye for e.g. hook mounting
- rubber surface on the wagon ensures good friction between the item and the skate
- the skate is articulated for ensuring easy turning
- CE marked

Max. load kg	Height mm	width mm	length mm	Base measures mm	Weight / pair appr. kg	Product code
3000	105	255	310	150x185	15	SIALU3TAN
6000	115	400	630	220x400	50	SIALU6TAN
12000	115	400	630	220x400	66	SIALU12TAN



SKATES 50T / SKATE KIT 60T

- heavy model skate
- 20 steel rolls
- moving extremely easily
- dimensions of table 417 x 305 mm
- height of skate 140 mm
- weight 67 kg

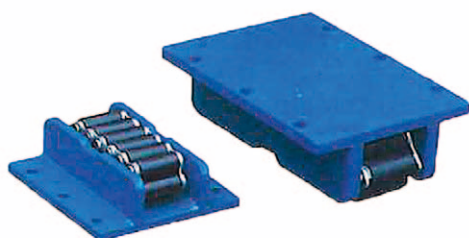
Product code: SIALU500S

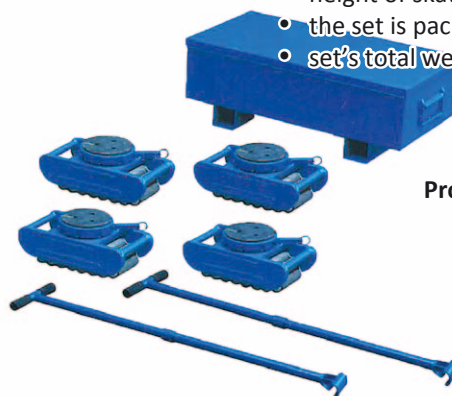

- heavy model complete skate kit
- include 4 pcs 15 t skates
- swiveling table with rubber surface
- 16 steel rolls in each skate
- set include also 2 pcs of handle bars
- skates moving extremely easily
- dimension of swivel top Ø150 mm
- height of skate 130 mm
- the set is packed in metal box
- set's total weight 108 kg



Product code: SIALU600SET

LOAD LEVER WITH ROLLER 5000KG

- for moving machines and equipment
- duration oiled metal wheels
- the rod can be used for lifting and moving
- CE marked

Max. load kg	Rod length mm	End width mm	Weight appr. kg	Product code
5000	1530	65	5	SIIRTAN50



ABT LIFTING TABLES / WORKING PLANES

- movable lifting tables / working planes that are lifted by pumping a hydraulic foot pedal
- two sizes
- rear wheel locking
- for assembly industry, installation and repair work etc.
- CE marked
- **not to be heat treated**

Maximum load	Table top min. height	Table top max. height	Table top measures	B	C	h	Weight	Product code
kg	H mm	H mm	W x L mm	mm	mm	mm	appr. kg	
300	315	910	830 x 500	500	1010	1100	78	NOSP250
500	430	1000	1010 x 520	520	1185	1130	118	NOSP500

NOSP250 (300kg)

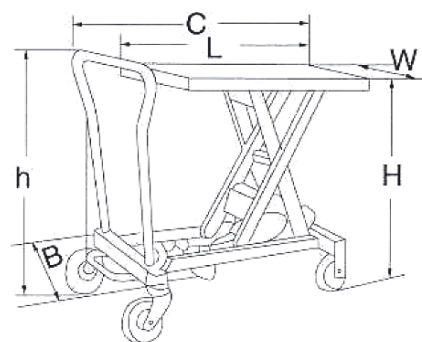
NOSP500 (500kg)

ABT ELECTRIC LIFTING TABLE

Electric scissor table for quick assembly and installation work. Lifts demanding and heavy loads without straining the user. Easy and quick lifting and lowering function. Two models, 250kg and 500kg.

Product code: NOSP250EL

Lifting capacity	250 kg
Lifting height, max.	900 mm
Lifting height, min.	288 mm
Working plane	815mm x 500mm x 50mm
Drive shaft height	1002 mm
Total length	1085 mm
Lifting time	< 10s
Lowering time	< 10s
Load wheel Ø	127 mm
Voltage	12 V
Weight	114 kg

Product code: NOSP500EL

Lifting capacity	500 kg
Lifting height, max.	900 mm
Lifting height, min.	275 mm
Working plane	1016mm x 610mm x 65mm
Drive shaft height	980 mm
Total length	1200 mm
Lifting time	< 15s
Lowering time	< 6s
Load wheel Ø	127 mm
Voltage	12 V
Weight	135 kg

ELECTROHYDRAULIC ABT LIFTING TABLES



- can be used in above floor or in floor pit applications
- three sizes: 1000kg; 2000kg and 4000kg
- for installation, repairs, packaging etc.
- operating voltage 3-stage / 380..400V
- control device (cable) with lifting and lowering functions as well as emergency stop
- equipped with protection frame, which prevents the table from lowering, if something gets in between the plates
- delivered completely assembled without plug
- CE marked
- **not to be heat treated**

Max. load kg	Min. height mm	Max. height mm	Table measures mm	Protection frame measures mm	Lifting time s	Weight kg	Product code
1000	205	1000	1300 x 820	1240 x 630	20	160	NOSP1000H
2000	230	1050	1600 x 1000	1220 x 785	20	268	NOSP2000H
4000	240	1100	2000 x 1200	1600 x 900	40	405	NOSP4000H

ELECTROHYDRAULIC ABT LIFTING TABLES WITH RAMP

- two sizes; 1000kg and 2000kg
- equipped with ramp
- for installation, repairs, packaging etc.
- operating voltage 3-stage / 380..400V
- separate control device with lifting and lowering functions as well as emergency stop
- equipped with protection frame, which prevents the table from lowering, if something gets in between the plates
- delivered completely assembled without plug
- CE marked
- **not to be heat treated**

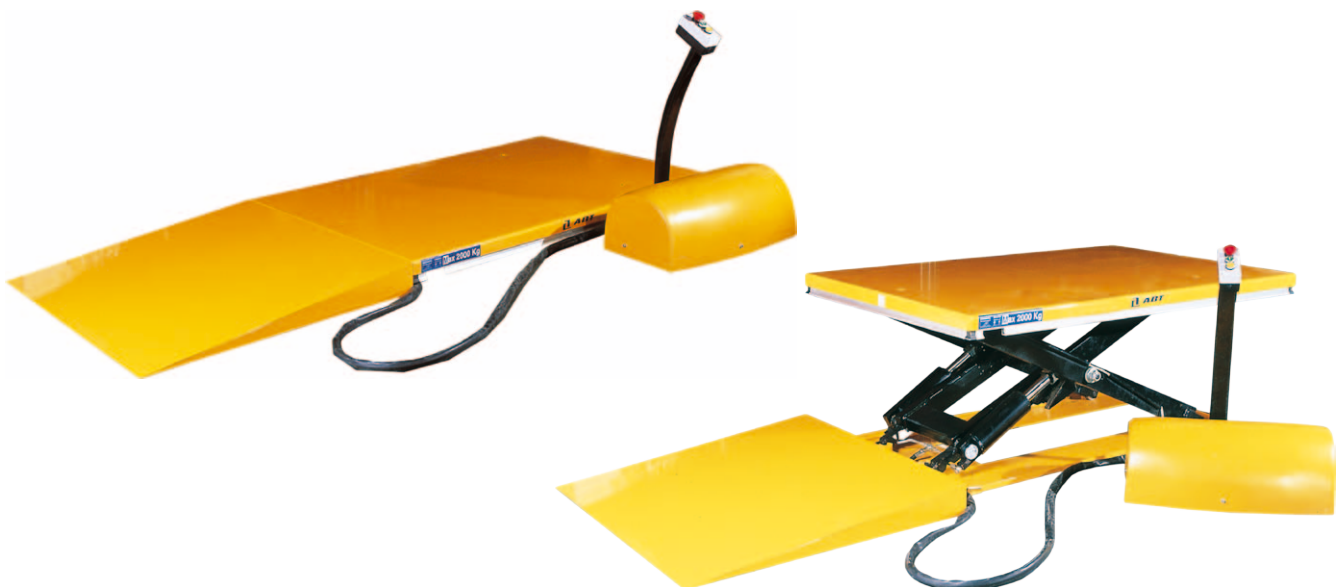
Max. load kg	Min. height mm	Max. height mm	Table measures mm	Lifting time s	Weight kg	Product code
1000	85	860	1450 x 1140	25	357	NOSP1000HL
2000	105	870	1600 x 1000	35	405	NOSP2000HL



HAND TROLLEYS



- two types
- for normal and level use
- normal model is equipped with foldable extension end and steel rims
- level model equipped with upward folding end

Max. Load kg	End width mm	End length mm	Cart height mm	Wheel type	Usage	Weight kg	Product code
250	410/330	305/600	1250	Air rubber	Normal	16,5	NOK250
75	350	410	1160	Solid rubber	Normal/step	16,2	NOK75POR

TRANSPORT ROLLEY 100 KG

- strong aluminium tubular frame cart is light weight, yet handles heavy loads.
- comfort-grip telescopic handle and simple push button operation retracts and folds noseplate automatically in seconds
- elat folding hand cart offers the carrying capacity of a large hand truck, but folds thinner than most luggage carts
- capacity 100 kg
- solid-rubber tyre
- wheels diameter 175 mm
- foot plate size 468 x 280 mm
- weight 5 kg

Product code: NOK100KT



ALUMINIUM TRUCK FOR PROFESSIONAL USE 150 KG

- light weight, easy to transport and operate
- easily convert, reduce operator fatigue
- capacity 150 kg
- solid-rubber tyre
- wheels diameter 260 mm
- weight 10 kg

Product code: NOK150AL

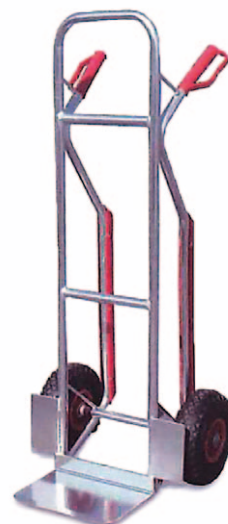

CONVERTIBLE HAND TRUCK FOR PROFESSIONAL USE 200 / 300 KG

- quickly convert from a 2-wheels upright to a 4-wheels platform truck with a single step on the foot pedal
- polished, low-friction noseplate surface is easy to load and unload
- capacity: hand truck 200 kg / platform hand truck 300 kg
- wheels diameter 260 mm
- weight 17 kg

Product code: NOK2030AL



PLATFORM HAND TRUCKS

- two types
- both are equipped with push handles that can be folded under the level
- solid rubber wheels
- fit into passenger car trunks

Max. Load kg	Truck level width mm	Truck level length mm	Level height mm	Weight kg	Product code
100	470	740	167	8,7	LAV100
300	616	916	209	16,8	LAV300



Ultra light
LAV100



LAV300

ABT PLATFORM HAND TRUCK, PLASTIC

- light and strong 2-level platform hand truck
- carrying capacity 250kg
- easy to clean, rustproof
- compartments for storing small items
- levels equipped with edges

Max. load kg	Upper level height mm	Lower level height mm	Distance between the levels mm	Wheel dimensions mm	Level dimensions mm L x W x H	Overall measures mm	Weight kg	Product code
250	850	150	500	125	790x435x110	1010x435x850	16	LAV2272

